

Important!

Audi

Please give copies to
all your Audi Technicians

Technical Bulletin

Subject: Radio, Removing and Installing

Group: 91

Number: 00-06

Model(s): A4, S4 with Symphony Radio

1999 ►

Date: Oct. 17, 2000

The following information will be integrated into the next AESIS release.

Service

Symphony radio, removing and installing

Note:

Obtain radio code for anti-theft radio before removing

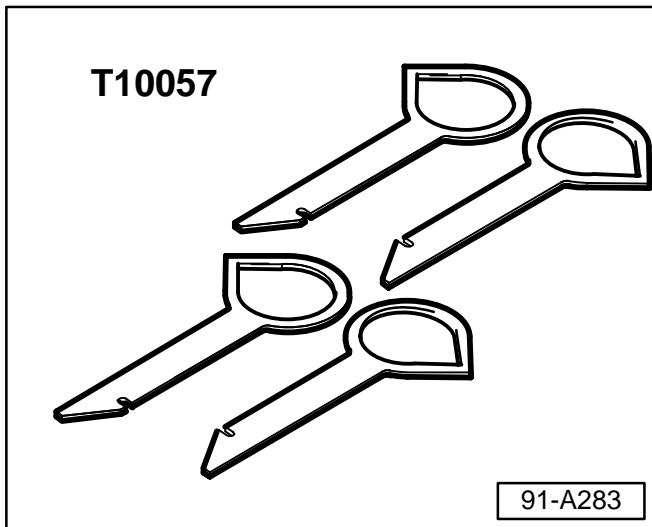

Required special tools and equipment

- ◆ T10057 removal tools (qty. 4 per set) are required for removing the Symphony radio

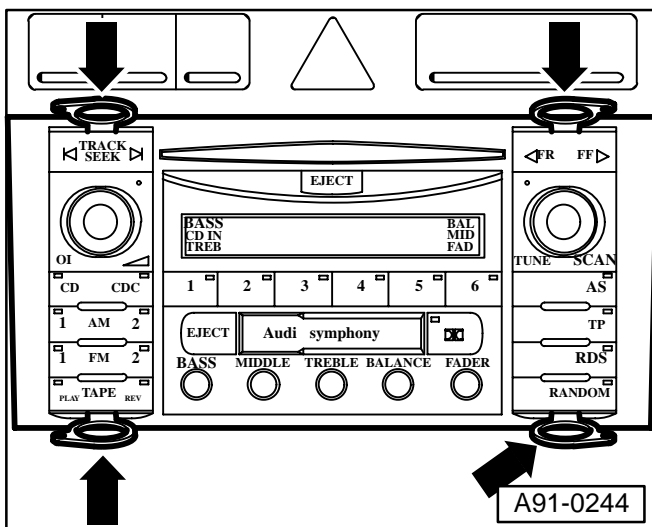

Radio, removing

- Insert radio removal tools into release slots (arrows) as shown until they engage.
- ◆ Top L - top and bottom left
- ◆ Top R - top and bottom right
- Pull radio out of instrument panel using grip rings on removal tools.
- Unlock and disconnect harness connectors.

(Cont. on Page 2)

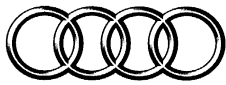

Important!

Audi

Please give copies to
all your Audi Technicians

Technical Bulletin

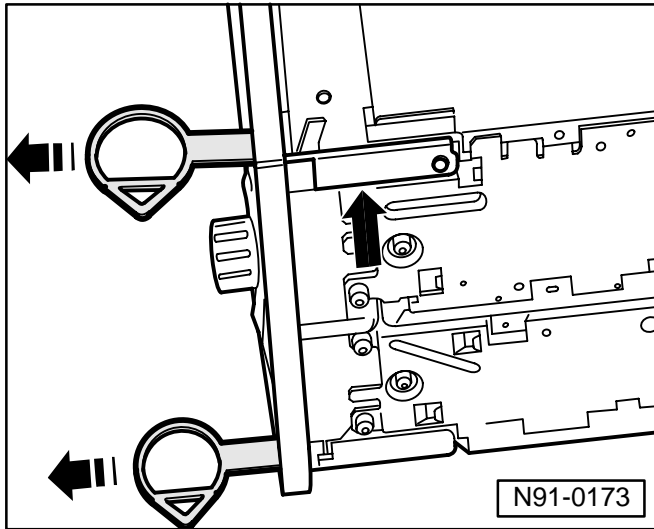

Radio removal tools, removing from radio

- Press locking latch (arrow) and remove radio removal tools towards front of radio.

Radio, installing

- Connect harness connectors to radio.
- Carefully slide radio into instrument panel opening until it engages in assembly frame (do not pinch or cut seal).
- Recode radio as necessary.

The radio must be installed and fully seated for anti-theft protection activation.

To check if anti-theft protection is working:

- Lock doors using either the key or the remote transmitter and listen for the alarm activation signal (horn chirp).

If alarm does not activate:

- Check that the radio is fully seated in the radio opening.